

MINOR KTF Slider Series

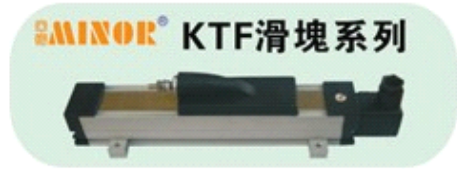

Built-in signal processing; DIN connector; Universal joint; Stroke range:0-2500mm; Analog output: 0-5V, 0-10V,4-20mA; Side slide traction structure, settle the length limit for installation. Application: injection moulding machine, large-scale hydraulic equipment, wooding machine etc.

KTF Slider Series	mm	75	100	125	150	175	200	225	250	275	300	350	400	450	475	500	550
Total Electrical Travel (T.E)	mm	80	105	130	155	180	205	230	255	280	305	355	405	455	480	505	555
Active Electrical Travel(A.E)	mm	75	100	125	150	175	200	225	250	275	300	350	400	450	475	500	550
Resistance Range $\pm 20\%$	k Ω	5.0															
Independent Linearity	$\pm \%$	0.05															
Mechanical Travel (M.T)	mm	82	107	132	157	182	207	232	257	282	307	357	407	457	482	507	557
Output		Voltage Divider															
Resolution		Infinite															
Operating Temperature	C°	-50 + 120															
Dimensions A	mm	224	249	274	299	324	349	374	399	424	449	499	549	599	624	649	699

KTF Slider Series	mm	600	650	700	750	800	850	900	950	1000	1150	1250	1500	1800	2000	2300	2500	
Total Electrical Travel (T.E)	mm	605	655	705	755	805	855	905	955	1005	1155	1255	1505	1805	2005	2305	2505	
Active Electrical Travel (A.E)	mm	600	650	700	750	800	850	900	950	1000	1150	1250	1500	1800	2000	2300	2500	
Resistance Range $\pm 20\%$	k Ω	10.0										20.0						
Independent Linearity	$\pm \%$	0.05																
Mechanical Travel (M.T)	mm	607	657	707	757	807	857	907	957	1007	1157	1257	1507	1807	2007	2307	2507	
Output		Voltage Divider																
Resolution		Infinite																
Operating Temperature	C°	-50 + 120																
Dimensions A	mm	749	799	849	899	949	999	1049	1099	1149	1299	1399	1649	1949	2149	2449	2649	

Dimensions for reference only and subject to change without prior notice.

Mechanical Dimension KTF 尺寸 KTF 滑塊式

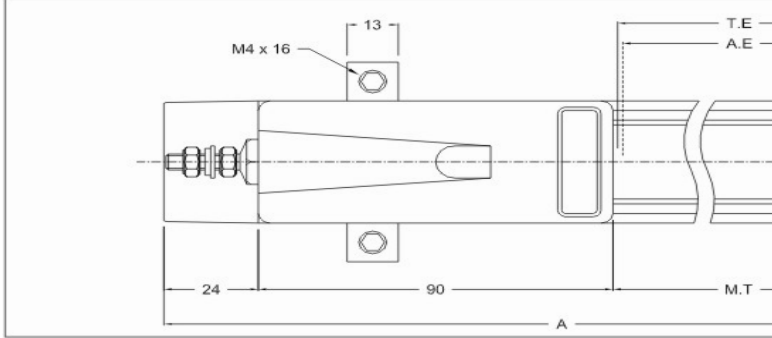

Ball and socket coupling 球窩連軸器

